

Better Magnets!

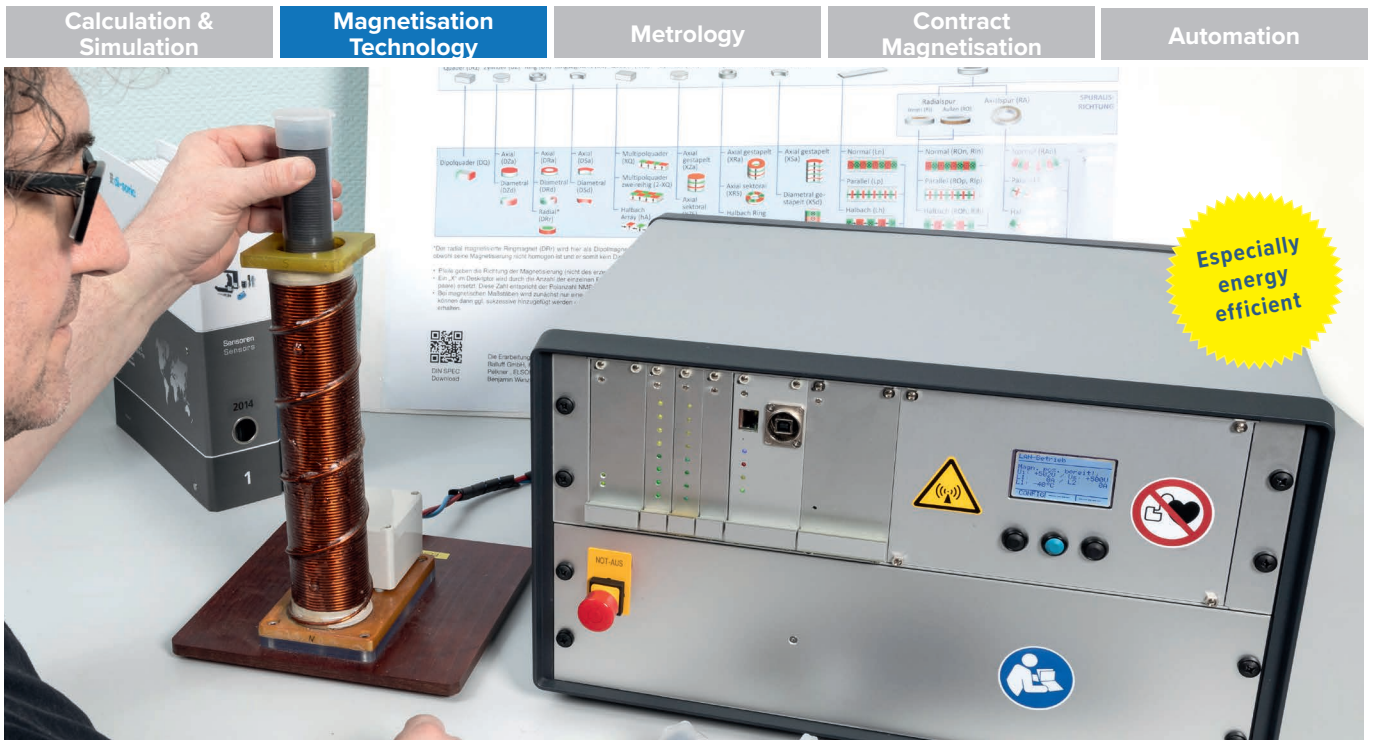

ELSOMAG® 230 C4 EEM Energy-efficient magnetizer

The ELSOMAG® 230C4 EEM magnetizers are microprocessor-controlled magnetizing devices with integrated diagnostic and measuring functions. They can be used for magnetizing all permanent magnet materials. They are particularly suitable for magnetizing plastic-bonded rare earth magnets. The ability to emit very short magnetizing pulses enables the production of multi-pole magnets with small pole pitches, as the magnetizing device is then subject to low thermal loads. The specially developed circuit of the power stage makes it possible to use the energy fed back

from the magnetizing device for the next magnetization, which almost doubles the magnetizing pulses per time unit and reduces energy consumption by more than 50 percent. This results in enormous advantages in production environments in which the waste heat from processes has to be dissipated. The magnetizing field strength can be adjusted via the charging voltage of the internal capacitor bank. User guidance is provided via the indicator lights and the display.

Features

- The ELSOMAG® 230C4 EEM magnetizers can deliver positive and negative current pulses to a connected magnetizing device as standard
- The current slew rate di/dt is up to 1000 A/ μ s
- A stabilization function is implemented as standard
- Control and diagnostics via Ethernet interface as standard, optionally via USB
- Control protocol according to SCPI as standard
- Optional digital interface (24 V, optocoupler) for integration into automated production systems, e.g. with „small PLC“
- Emergency stop circuit and safety functions, e.g. switching off the magnetizing function when the device reaches a limit temperature
- Mains switch/cold appliance socket combination with fuse and mains filter

Your Benefits

- Fast, precise magnetization of motor and sensor magnets
- Calibration of magnets or magnetic systems
- When operating two magnetizing devices on one device, cycle times of 2 s per device can be achieved
- Integrated measurement and evaluation of the magnetizing current
- The magnetizer is designed for continuous 3-shift operation with an availability of > 95 %
- Programmable charging voltage (charging voltage accuracy ± 1 %)
- Scalable performance due to different capacitor configuration

Highlights

TCP/IP interface for integration into an automated system

USB interface for software updates

Digital 24 V interface for automation via a PLC (rear of device)



High energy-efficiency

An energy-saving design and the use of energy recovery enable a high operating speed due to reduced power loss combined with lower heating of the magnetizing device.

High power density - easily scalable

As a desktop device, the ELSOMAG® 230 C4 EEM offers a maximum pulse energy of 2400 Ws and magnetizing currents of up to 10 kA in a very compact design.

Ease of use

Great attention was paid to clarity and simple operation when designing the user interface. The device can be operated without expert knowledge.

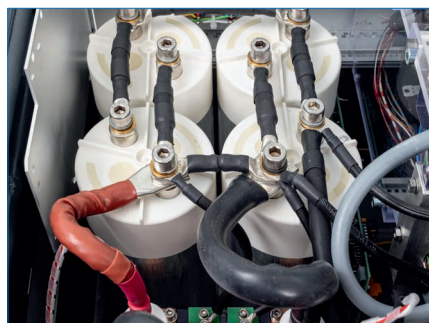

Capacitor bank (scalable from 720 μ F - 2880 μ F)

Microcontroller for controlling the magnetizer and the interfaces

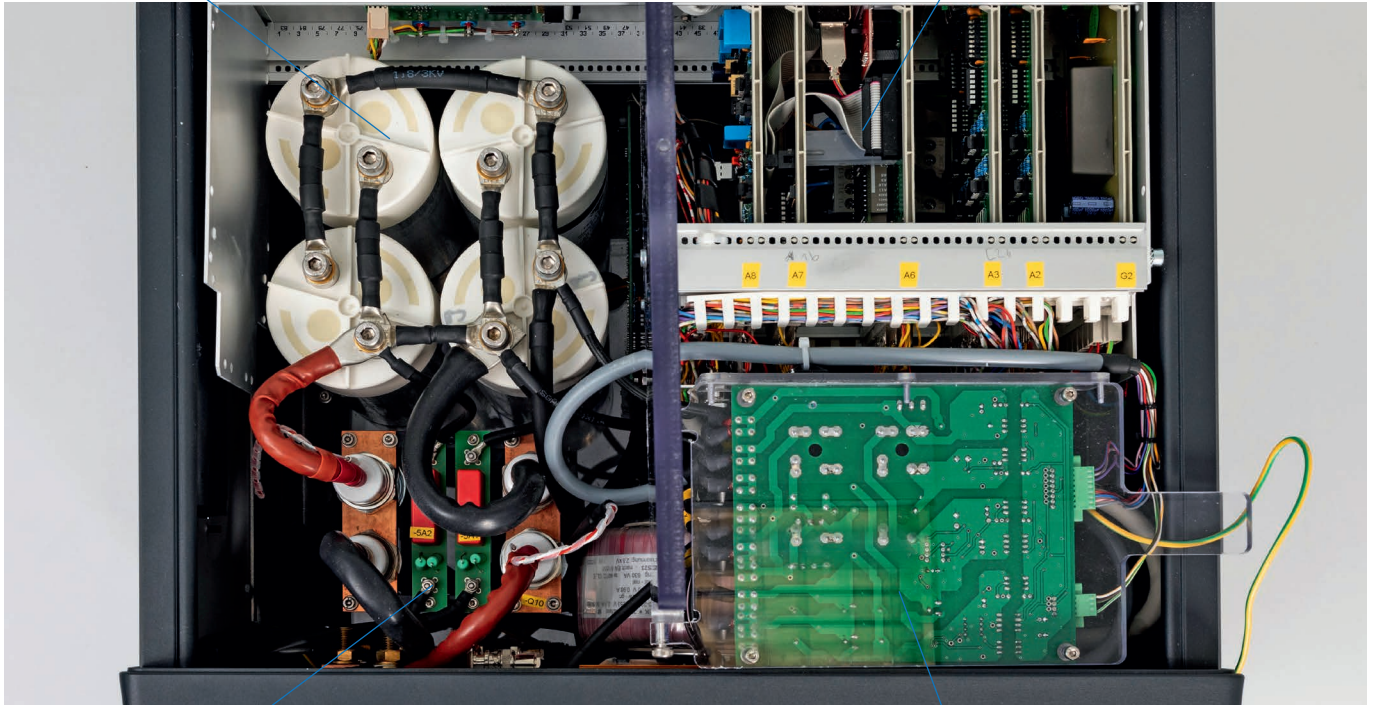

High-current switch for positive and negative magnetizing pulses

Charging circuit for positive or negative charging of the capacitor bank

Precision

High-quality components enable very precise magnetization of $\leq 1\%$ or calibration of motor or sensor magnets.

Easy integration

Ethernet and USB interfaces as well as an optional I/O interface allow the device to be easily integrated into automated production systems.

Integrated diagnostics and metrology

To ensure reliable 24/7 operation, the device has integrated measurement technology and diagnostic software.

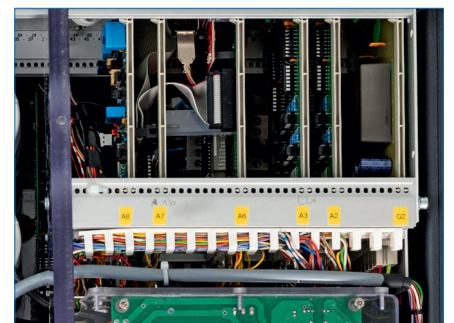

Technical Data

Parameter	Value
Maximale pulse energy	2400 Ws (depending on expansion stage)
Maximum current during magnetisation	10 kA (< 3 ms)
Charging time of the capacitor	< 8 s (at maximum charging voltage)
Nominal voltage	230 V / 50 Hz (+ 15 % / - 10 %)
Rated current	3 A
Rated power	0.7 kW
Protection	Circuit breaker B 16 A
Machine capability C_{mk}	> 2,0
Process capability C_{pk}	> 1.67
Housing colour	RAL 7021
Weight	38.5 kg

Dimensions (in mm)

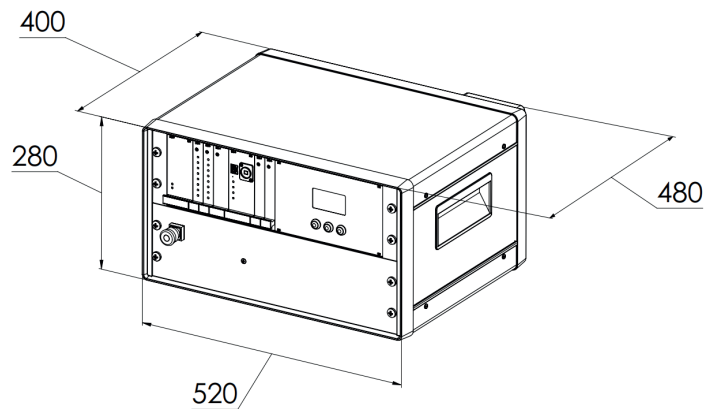

Accessories

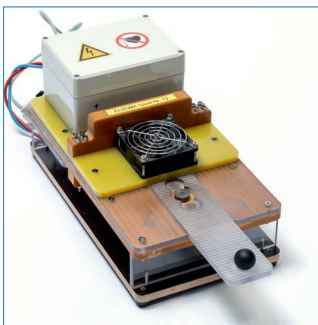

Fixtures

- Devices can be customized (size, shape, release, etc.).

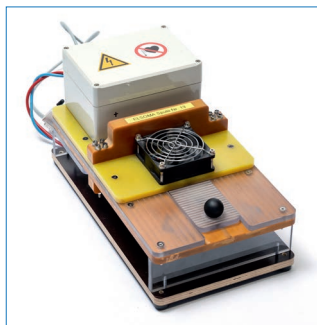

Parameterization software

- ELSOMA offers customized software for parameterizing the device.



Production data acquisition

- ELSOMA offers software for the recording of production data on any end device, e.g. PC or tablet.

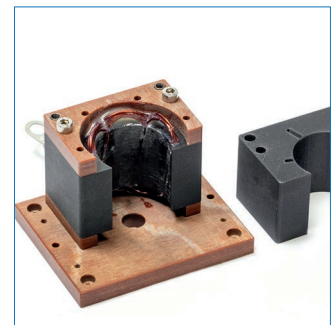

Areas of application: Magnet manufacturers | magnet users | encoder manufacturers | sensor manufacturers | motor manufacturers | automotive suppliers